

Table Template Instructions



Please follow these simple instructions to successfully prepare your router table for Next Wave CNC RS1000 PRO.

1. You can safely and securely attach the Template to the tabletop with double-sided tape or clamps in the location where you want the opening.

If using clamps, make sure that they won't obstruct the router base during machining.

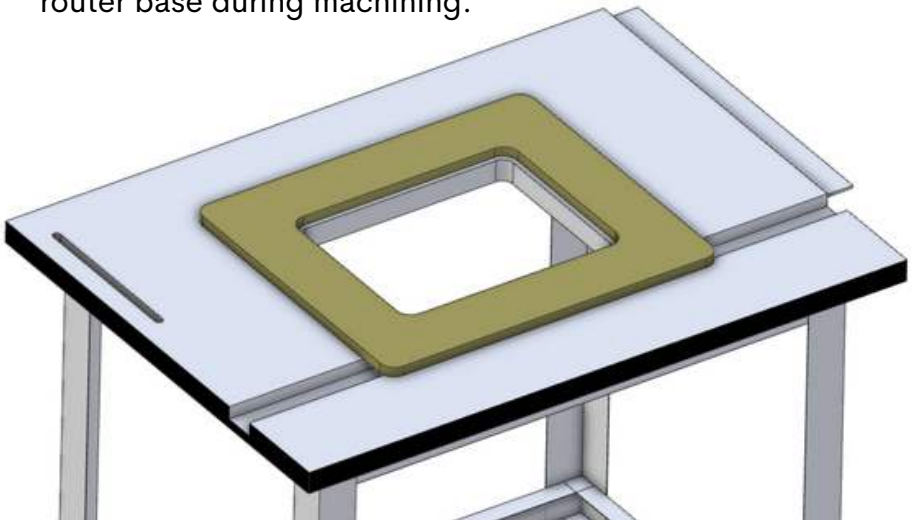

SKU 20190

Table Template Instructions

2. In a handheld router, use a template-style router bit with bearing and set it to the thickness of your table. Guide the template bits bearing tightly around the template, removing all waste material and leaving you with a $9\frac{1}{4}'' \times 11\frac{3}{4}''$ opening.

Rout through the inside opening of the template, making sure to keep the bit's guide bearing tight against the template all the way around.



3. Install the Leveling Kit to your router table by following the Instructions included with your RS1000 Pro.

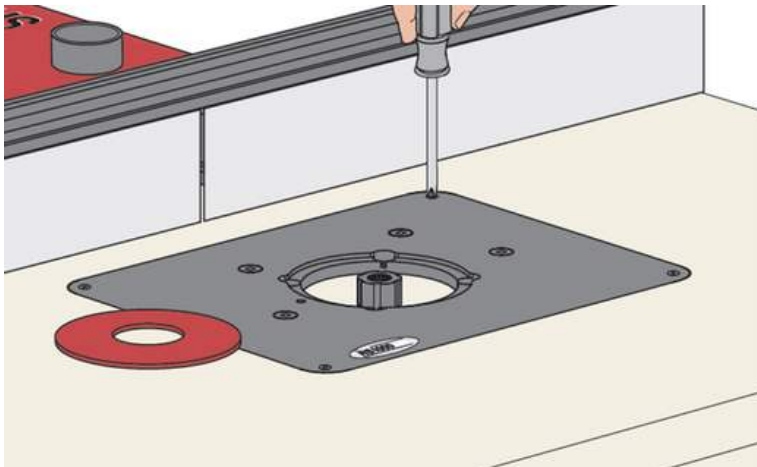

SKU 20190